

REVISION HISTORY

REV	DESCRIPTION	DATE	APPROVED
A	Initial Release	1/29/2014	RP
B	Add Reel Size and Cleaning Kit Options	5/12/2021	SG

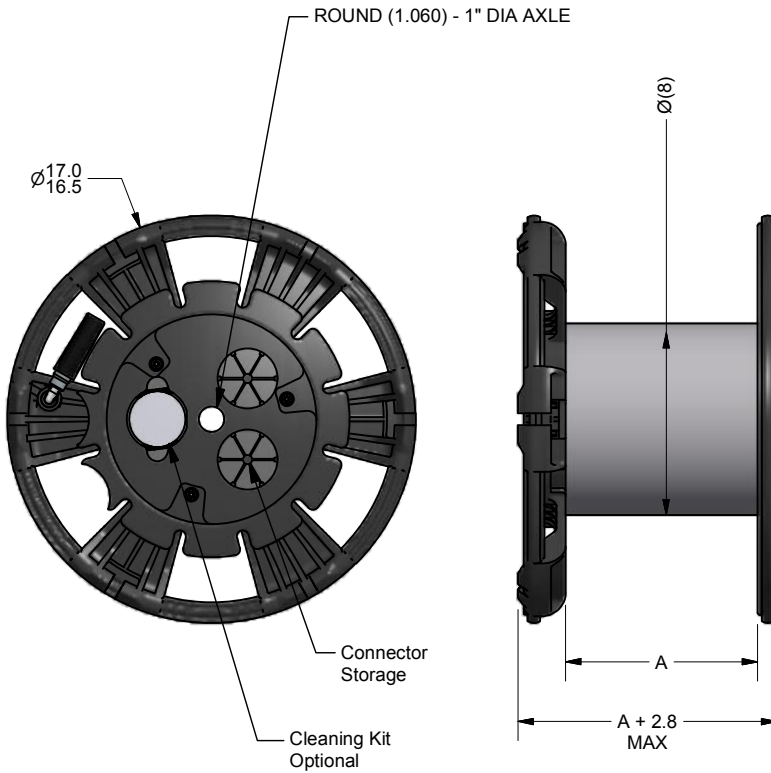

B

REEL CONFIGURATIONS "ACR-XXXX-B-y-1"		
Size "XXXX"	Length "A"	Cleaning Kit "y"
0300	5.0	X - None
0500	8.0	A - 4/12 CH, C83526 (TFOCA 2)
0750	12.0	B - Expanded Beam
1000	16.0	E - 4/12 CH, EZ-Mate
1250	20.0	F - F-Link
		H - SMPTE
		J - 6/24 CH, EZ-Mate
		N - M28876
		P - Pierside

NOTES: UNLESS OTHERWISE SPECIFIED

- MATERIAL:  
 Reel: High Impact, FR Grade, UV Resistant Thermoplastic, Color Black  
 Hub: Aluminum, Black Anodized  
 Hardware: Stainless Steel
- Cosmetic surface variations related to injection molding which do not affect fit or function are acceptable.

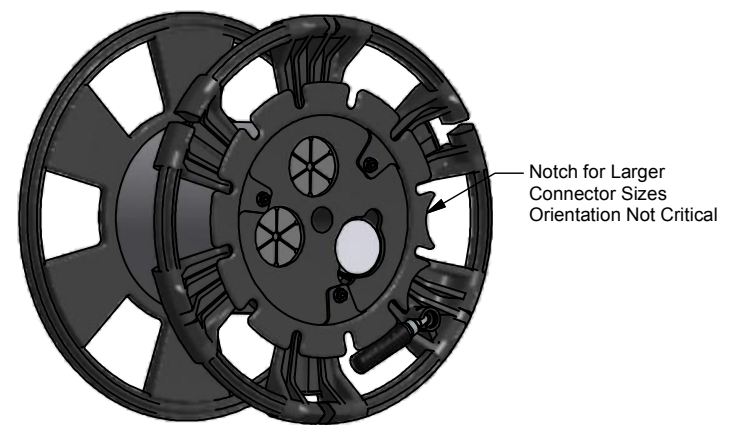

<p>THIRD ANGLE PROJECTION</p>	DRAWN N. GUIFFAULT 1/29/2014	<p>1700 Capital Ave., Suite 150                  Plano, TX-75074                  (972)509-1500                  www.occfiber.com</p> <p>OPTICAL CABLE CORPORATION FORMERLY APPLIED OPTICAL SYSTEMS</p>
	CHECKED RP 1/29/2014	
	APPROVED RP 1/29/2014	
TITLE PRODUCT DRAWING, REEL ACR-0300 & ABOVE		
THIS DOCUMENT IS THE PROPERTY OF OPTICAL CABLE CORPORATION AND CONTAINS PROPRIETARY INFORMATION AND SHALL NOT BE DISCLOSED TO OTHERS OR DUPLICATED IN PART OR FULL OR USED FOR ANY OTHER PURPOSES OTHER THAN IN SUPPORT OF OUR VENDOR/PURCHASER RELATIONSHIP	TOLERANCES Unless Otherwise Specified LINEAR ANGULAR .X ± .05 X ± 5' .XX ± .020 X.X ± 1' XXX ± .010	
	All Dimensions are in inches DO NOT SCALE DRAWING	
	SIZE A	DWG NO ACR-XXXX-B-X-1
SCALE	CAGE CODE: 335J8 DESIGN STATUS Released	SHEET 1 OF 1