

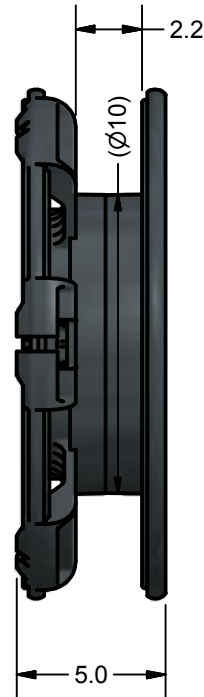

REVISION HISTORY			
REV	DESCRIPTION	DATE	APPROVED
A	Initial Release	5/22/2014	RP

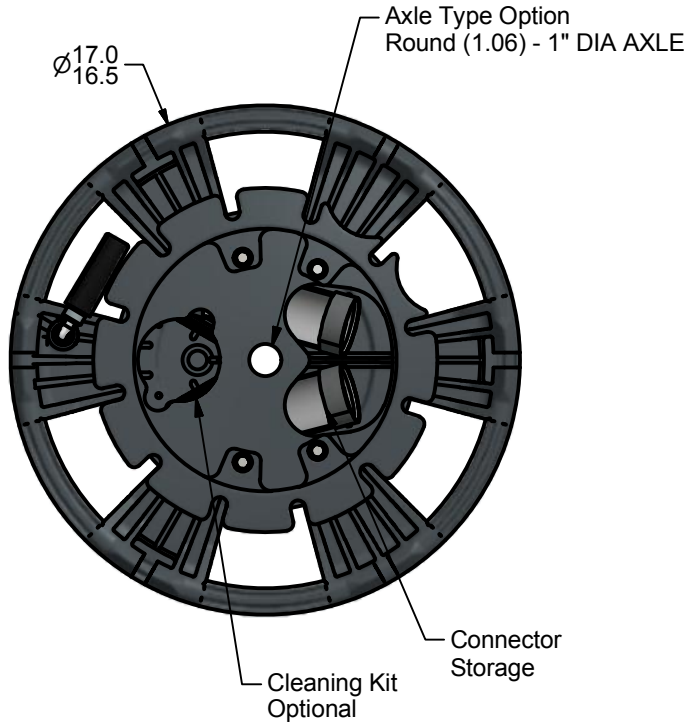

Part Number	Cleaning Kit "X"
ACR-0100-B-X-1	X - None
	M - 4/12 CH 83526 TFOCA2
	H - 6/24 CH EZ-Mate
	P - Navsea Pierside
	H - Hermaphroditic SMPTE
	F - F-Link
	N - M28876
	T - 2 CH 83526 TFOCA
	E - 4/12 CH EZ-Mate
	B - Expanded Beam
	Q - 2.5 mm Ferrule Connectors
S - 1.6-2.0 mm Ferrule Connectors	
U - 1.25 mm Ferrule Connectors	

NOTES: UNLESS OTHERWISE SPECIFIED

- MATERIAL:  
Reel: High Impact, UV Resistant Thermoplastic, Black  
Hardware: Stainless Steel
- Cosmetic surface variations related to injection molding which do not affect fit or function are acceptable.

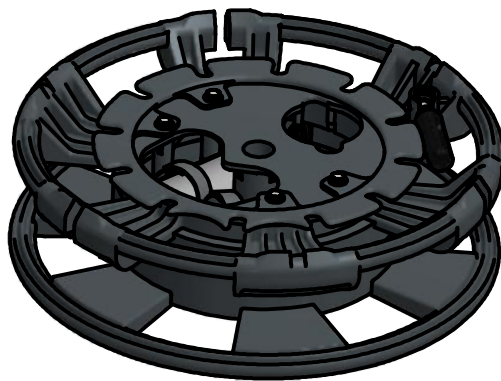

<p>THIRD ANGLE PROJECTION</p>	DRAWN S. Gondakyan	5/22/2014
	CHECKED RP	5/22/2014
	APPROVED RP	5/22/2014

**OCC**  
 OPTICAL CABLE CORPORATION FORMERLY APPLIED OPTICAL SYSTEMS  
 1700 Capital Ave., Suite 150  
 Plano, TX-75074  
 (972)509-1500  
 www.occfiber.com

THIS DOCUMENT IS THE PROPERTY OF OPTICAL CABLE CORPORATION AND CONTAINS PROPRIETARY INFORMATION AND SHALL NOT BE DISCLOSED TO OTHERS OR DUPLICATED IN PART OR FULL OR USED FOR ANY OTHER PURPOSES OTHER THAN IN SUPPORT OF OUR VENDOR/PURCHASER RELATIONSHIP	<b>TOLERANCES</b> Unless Otherwise Specified LINEAR ANGULAR .X ± .05 X ± 5' .XX ± .020 X.X ± 1' XXX ± .010	
	All Dimensions are in inches DO NOT SCALE DRAWING	
	SIZE A	DWG NO ACR-0100-B-X-1
	SCALE	CAGE CODE: 335J8

TITLE REEL, ACR-0100		
REV A	DESIGN STATUS Released	SHEET 1 OF 1

