

REVISION HISTORY			
REV	DESCRIPTION	DATE	APPROVED
A	Initial Release	6/30/2009	NG
B	Material change: Aluminum --> Steel Two L-Shape Handles --> One U-Shape handle	10/22/2010	NG
B1	Logo Update	3/9/2012	RP
C	Add Weight Info	6/10/2015	RP
D	Update P/N Configuration Table	9/8/2016	RP
D1	Add 500 m Option for Weight	6/27/2017	RP
D2	Clarify Color	11/13/2019	SG

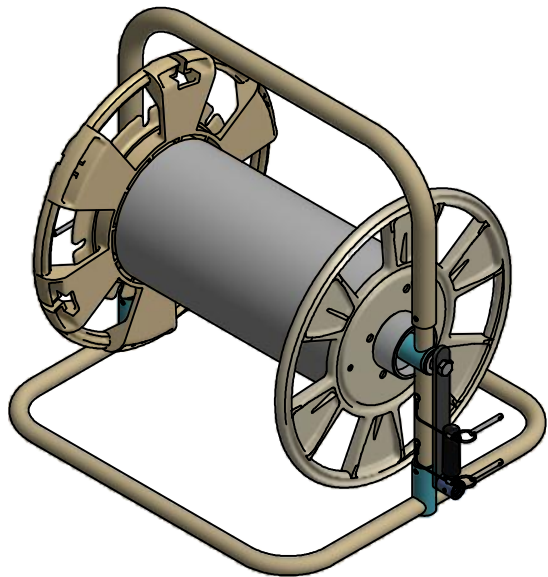

Weight per Reel Size	
Reel Size	Weight (lbs)
AFO 0500	18
AFO 0750	20
AFO 1000	20
AFO 1250	22

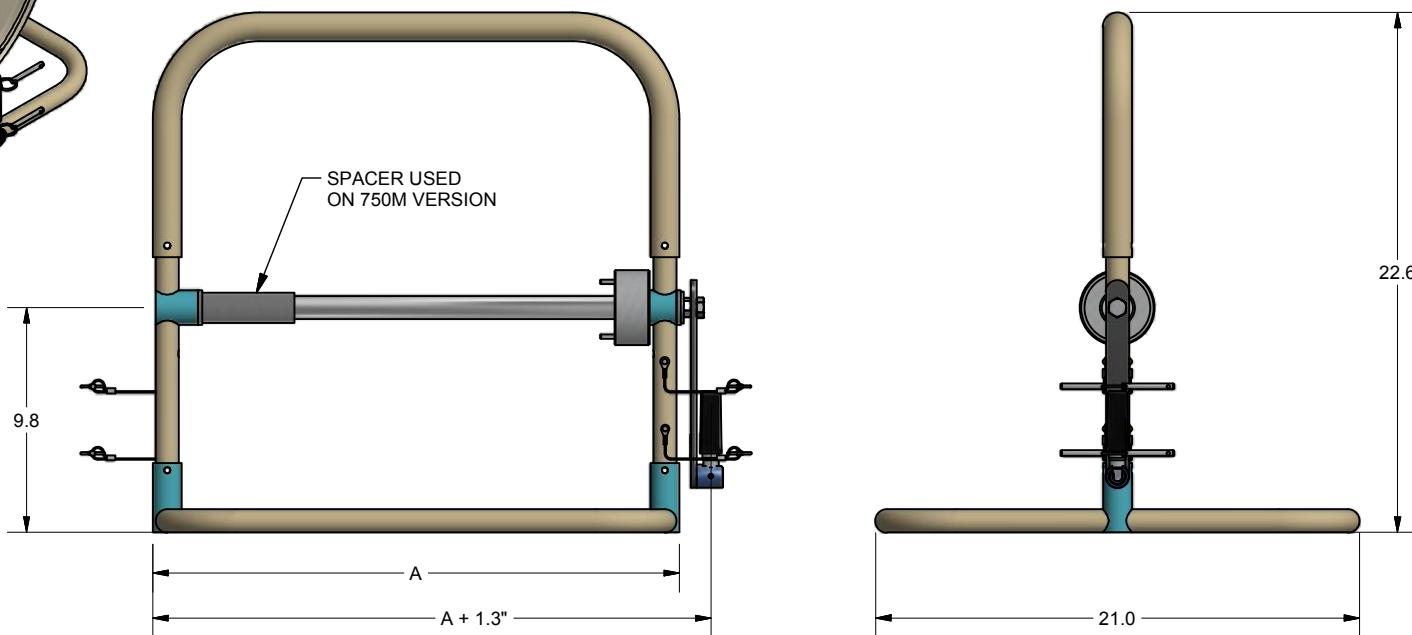

NOTES: UNLESS OTHERWISE SPECIFIED

- MATERIAL:
 FRAME: MILD STEEL
 SHAFT ASSEMBLY: ALUMINUM OR MILD STEEL
 HARDWARE: STAINLESS STEEL
- COLOR: PER CONFIGURATION



PART NUMBER CONFIGURATION					
PART NUMBER	SIZE		COLOR		
	yyyy	Description	A	c	Description
ARA-yyyy-X-X-c	0500	AFO 0500 REEL	14.9	T	Desert Tan
	0750	AFO 0750 REEL	22.9	B	Black
	1000	AFO 1000 REEL	22.9	G	Green
	1250	AFO 1250 REEL	26.9		

<p>THIRD ANGLE PROJECTION</p>	DRAWN N. Guiffault	6/30/2009
	CHECKED RP	7/3/2009
	APPROVED RP	7/3/2009
<p>THIS DOCUMENT IS THE PROPERTY OF OPTICAL CABLE CORPORATION AND CONTAINS PROPRIETARY INFORMATION AND SHALL NOT BE DISCLOSED TO OTHERS OR DUPLICATED IN PART OR FULL OR USED FOR ANY OTHER PURPOSES OTHER THAN IN SUPPORT OF OUR VENDOR/PURCHASER RELATIONSHIP</p>	<p>TOLERANCES</p> <p>Unless Otherwise Specified</p> <p>LINEAR ANGULAR</p> <p>.X ± .05 X ± 5°</p> <p>.XX ± .020 X.X ± 1°</p> <p>XXX ± .010</p>	
	<p>All Dimensions are in inches</p> <p>DO NOT SCALE DRAWING</p>	

<p>OPTICAL CABLE CORPORATION FORMERLY APPLIED OPTICAL SYSTEMS</p>		1700 Capital Ave., Suite 150 Plano, TX-75074 (972)509-1500 www.occfiber.com	
TITLE T-FRAME, NO BRAKE - PRODUCT DRAWING			
SIZE A	DWG NO ARA-YYYY-X-X-C	REV D2	
SCALE	CAGE CODE: 335J8	DESIGN STATUS Released	
		SHEET 1 OF 1	