



CVH-2000 Version: 1

14-Slot Media Converter Chassis

The LevelOne CVT-2000 media converter chassis is able to host up to 14 media converters. The chassis supports LevelOne FVT-2001/2002/2201/2401 and GVT-2000/2001 Media Converts. All converters are individually secured into the chassis and can be hot-swapped for maximum connection reliability.

The dual power supplies ensure continuous network operation. The Chassis is a standard 19-inch rack-mountable size that easily fits into a server rack.



- 1. Converter Chassis Slot
- 2. Power On / Off switch
- 3. Power Socket

Key Features

- Supports 14 slots for various type of Media Converters
- 2 redundant power units supported
- Converter module hot-swappable
- -10°C ~ 55°C operating temperature range
- 19-inch metal housing

Compatible With



FVT-2001

10/100BASE-TX to 100BASE-FX MMF SC Converter, 2km

**FVT-2002**

10/100BASE-TX to 100BASE-FX MMF ST Converter, 2km

**FVT-2201**

10/100BASE-TX to 100BASE-FX SMF SC Converter, 20km

**FVT-2401**

10/100BASE-TX to 100BASE-FX SMF SC Converter, 40km

**GVT-2000**

10/100/1000BASE-T to 1000BASE-X SFP Converter

**GVT-2001**

10/100/1000BASE-T to 1000BASE-SX MMF SC Converter, 550m

Specifications

System Specifications

Connectors and Cabling:

14 x converter slots

Indicator:

Power A; Power B

Power:

Power Consumption: < 60W

AC Power Input: 100~265VAC, 50~60Hz

Redundant Power

Physical Specifications

Dimensions (W x D x H mm):

427 x 315 x 91mm(2U, 19")

Weight (g):

4200 g

Environment

Temperature (°C):

Operating: 0°C ~ 50°C

Storage: -10°C ~ 70°C

Humidity (Non-condensing):

Operating: 5% ~ 90%

Others

Approval and Compliance:

FCC / CE

Deployment:

19-inch rack-mountable

Diagram

Dimension Diagram

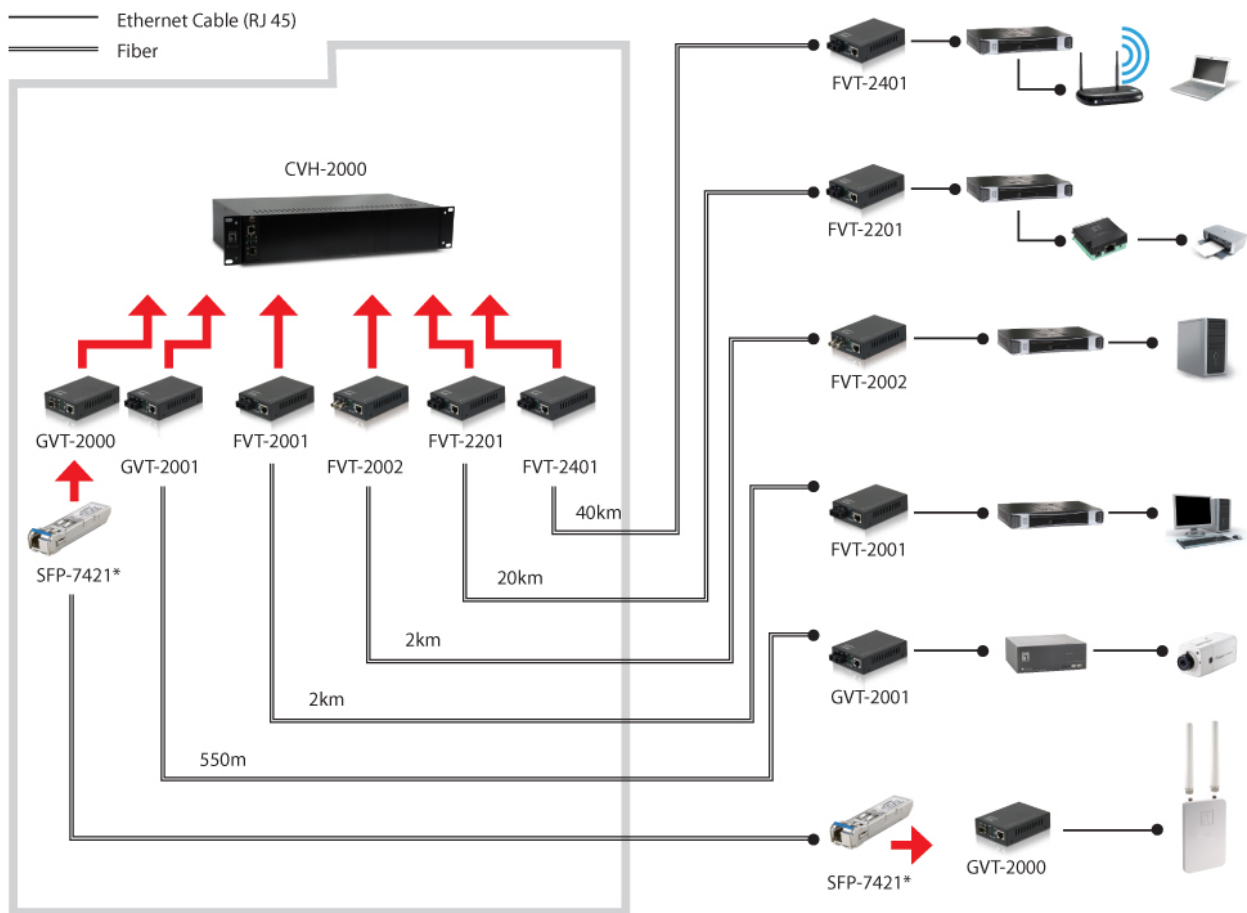

* In above example diagram, converter modules at local and remote ends should be paired for proper connectivity, and the distance mainly depends on cable and transceiver selection accordingly.

Order Information

CVH-2000

Package Contents

Power Cord

Module Brackets

Quick Installation Guide

No responsibility for any errors or omissions. All mentioned brand names are registered trademarks and property of their owners.
Copyright © Digital Data Communications GmbH, Germany. All Rights Reserved.